



Preformers

Cannon has supplied several preformers to **mold carbon fiber** and **fiberglass** before injection of polyurethane or epoxy.

The preformer is necessary in case of a high volume production environment and where the part has **complex 3D geometries** to improve part quality and to reduce the formation of wrinkles and folds. The preformer can handle over seven layers of different products and also provides a **high degree of flexibility** with the different part sizes, shapes, and "draw" requirement with its **"hold/slip" frame**.

The hold/slip frame allows the manufacturer to adjust the tension of the fabric to determine how much slip or stretch will occur to optimize the part shape.

Carbon fiber mats can be held with servo controlled grippers that can be programmed to follow the edge of the stack (multi-layer material) during forming.

Cannon equipment preforms fiberglass and carbon fiber in production and the lab environment.



EXAMPLE OF A PREFORMER DATA SHEET

FEED	Nr. of individual material coils	1-8
	Material width	2000 mm
HEATING	Type	2-side IR
	Specific heating power	18 kW/m ²
TRANSFER	Type	Front/back servo grippers
	Number	10 each side
PREFORMING PRESS	Platen dimensions	2000 x 1600 mm
	Clamping force	50-500 kN
	Min. daylight	600 mm
	Max. daylight	1400 mm
	Upper platen vertical stroke	800 mm
	Hold-slip frame vertical stroke	850 mm
	Hold slip frame clamping force	40 kN
	Shuttling stroke of lower platen	2200 mm

MAIN ADVANTAGES

- Wrinkle free parts
- Controlled material flow
- Minimal material consumption
- Flexibility
- High production
- Complete turnkey system





Main Components

- Manual or Automatic Loading Station
- Horizontal (Infrared or contact plates) Oven
- Gripping and Transferring System
- Preforming Press
- Control System
- Preforms fiberglass and carbon fiber

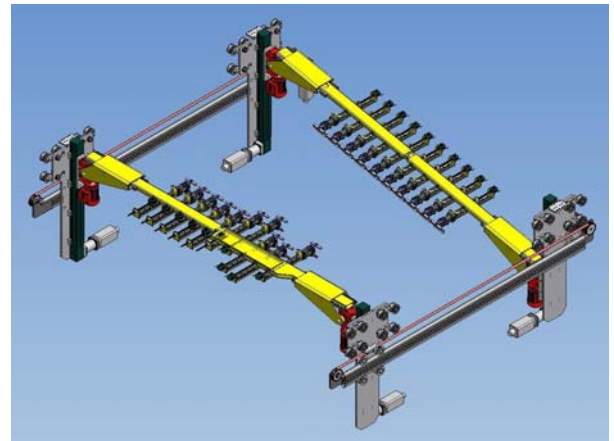

Servo controlled grippers



"hold/slip" frame

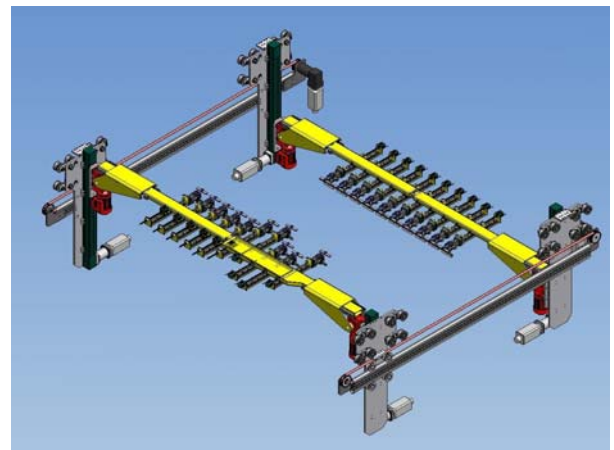

PREFORMER - PR16 Cannon Communication 09/2013 - PS/ED